

C12R

Top Workability Maintenance Option Spec

Spec

Dimensions

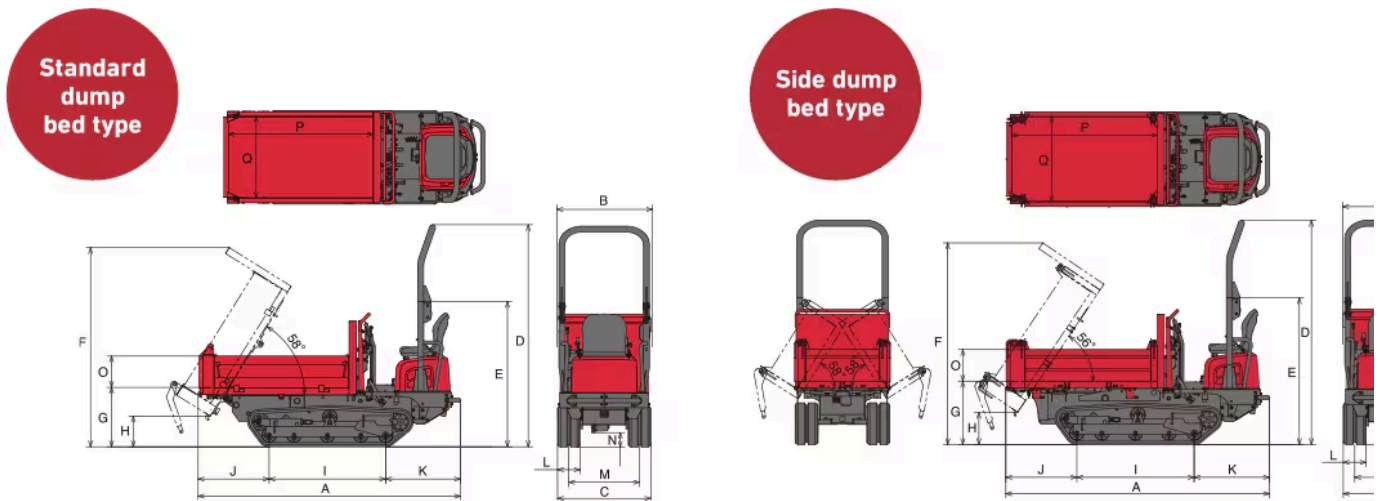

Unit: m

	A	B	C	D	E	F	G	H	
Standard type	2650 <8'8">	950 <3'1">	950 <3'1">	2250 <7'5">	1470 <4'10">	2015 <6'7">	600 <1'11">	310 <1'0">	1 <3
Side dump type	2650 <8'8">	960 <3'2">	950 <3'1">	2250 <7'5">	1470 <4'10">	2025 <6'8">	635 <2'1">	325 <1'1">	1 <3
	J	K	L	M	N	O	P	Q	
Standard type	710 <2'4">	760 <2'6">	230 <9">	720 <2'4">	150 <6">	320 <1'1">	1470 <4'10">	830 <2'8">	
Side dump type	710 <2'4">	760 <2'6">	230 <9">	720 <2'4">	150 <6">	315 <1'0">	1470 <4'10">	860 <2'10">	

Specifications



Model			C12R-C		
Carrier Type			Standard dump bed type	Side dump bed type	
Operating Weight	Net, Unloaded		kg <lbs>	1010 <2227>	
Engine	Type		Vertical 2 cylinder, water-cooled diesel		
	Model		402J-05 IG84557R		
	Rated Output/ Revs		kW <hp>/ rpm	7.7 <10.4> / 2800	
Transmission			Hydrostatic & Reduction gear		
Under Carriage	Crawler Width		mm <in>	230 <9.06>	
	Min. Ground Clearance		mm <in>	150 <5.91>	
	Ground Contact Pressure	w/o load	kPa <PSI>	18.2 <2.65>	19.9 <2.88>
		w/ load	kPa <PSI>	39.0 <5.66>	40.7 <5.89>
Brake	Service Brake	Type	Mechanical wet multiple disk		
		Operation	Pedal, mechanical		
	Parking Brake	Type	Common with service brake		
		Operation	Lever, pedal lock		
Performance	Max. Payload		kg <lbs>	1150 <2540>	
	Dumping Angle	Rear	degrees	58	56
		Side	degrees	-	58
	Dump Clearance at Rear Dump		mm <in>	310 <1'>	325 <1'11">
	Dump bed Capacity	Struck	m ³ <cu.ft.>	0.040 <1.41>	
		Heaped	m ³ <cu.ft.>	0.52 <18.4>	
	Travel Speed	Forward	km/h <MPH>	0 - 5.5 <0 - 3.4>	
Reverse		km/h <MPH>	0 - 5.5 <0 - 3.4>		
Hydraulic System For Dump	Pump		Gear		
	Control Valve		Single spool		
Fuel tank capacity			L <Gals>	14.5 <3.83>	

What's New



Excellent Footwork & Armwork



MADE FROM THE HEART